

Turkey Problems

A movie stuntman (mass 80.0 kg) stands on a window ledge 5.0 m above the floor. Grabbing a rope attached to a chandelier, he swings down to grapple with the movie's villain (mass 70.0 kg), who is standing directly under the chandelier. The coefficient of kinetic friction of their bodies with the floor is $\mu_k = 0.300$. (Assume that the stuntman's center of mass moves downward 5.0 m. He releases the rope just as he reaches the villain.)

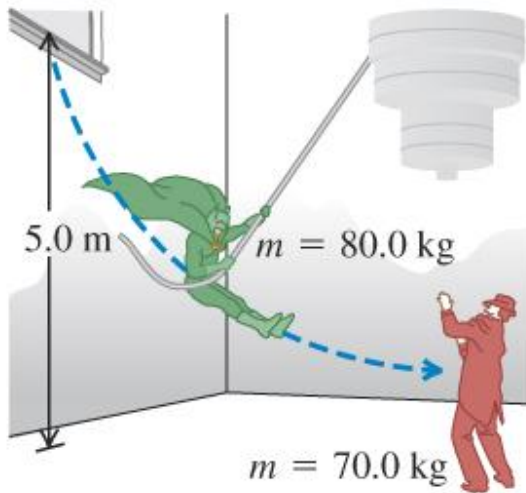

Turkey Problems

A 12.0 g rifle bullet is fired with a speed of 380 m/s into a ballistic pendulum with mass 9.00 g, suspended from a cord 70.0 cm long. Find the vertical height through which the pendulum rises.

Turkey Problems

The Great Sandini is a 60-kg circus performer who is shot from a cannon (actually a spring gun). You don't find many men of his caliber, so you help him design a new gun. This new gun has a very large spring with a very small mass and a force constant of 1400 N/m that he will compress with a force of 5600 N. The inside of the gun barrel is coated with Teflon, so the average friction force will be only 47 N during the distance of 4.0 m that he moves in the barrel. At what speed will he emerge from the end of the barrel, a distance 1.7 m above his initial rest position?

Turkey Problems

Consider the system shown in the figure. The rope and pulley have negligible mass, and the pulley is frictionless. The coefficient of kinetic friction between the 8.00-kg block and the tabletop is 0.300. The blocks are released from rest. Use both energy and force to calculate the speed of the 6.00-kg block after it has descended 1.50 m.

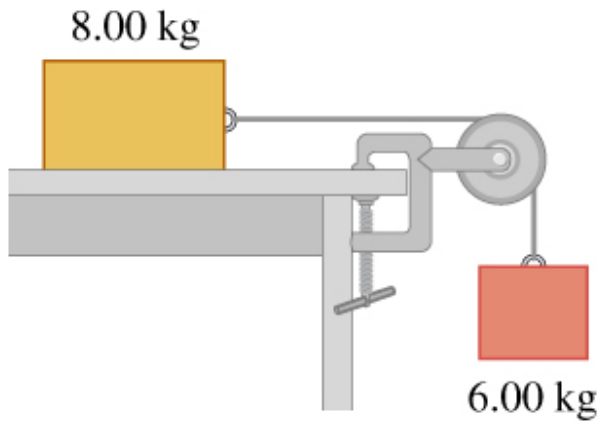

Turkey Problems

Two blocks with masses 4.00 kg and 8.00 kg are connected by a string and slide down a 30.0° inclined plane (see the figure). The coefficient of kinetic friction between the 4.00-kg block and the plane is 0.25; that between the 8.00-kg block and the plane is 0.35.

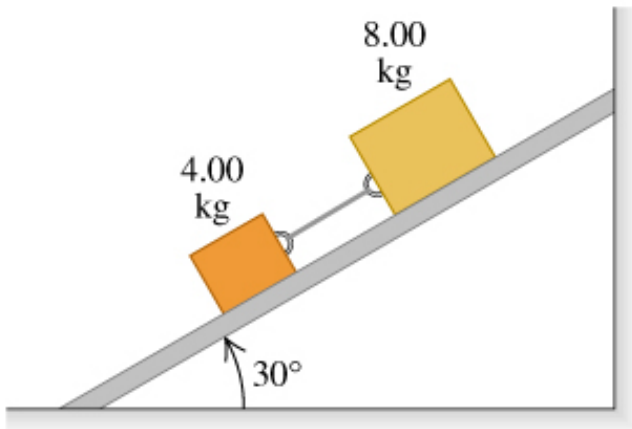

Turkey Problems

You are on the roof of the physics building, 46.0 m above the ground. Your physics professor, who is 1.80 m tall, is walking alongside the building at a constant speed of 1.20 m/s. If you wish to drop an egg on your professor's head, how far from the building should the professor be when you release the egg? Assume that the egg is in free fall

Turkey Problems

A helicopter carrying Dr. Evil takes off with a constant upward acceleration of 5.0 . Secret agent Austin Powers jumps on just as the helicopter lifts off the ground. After the two men struggle for 10.0 s, Powers shuts off the engine and steps out of the helicopter. Assume that the helicopter is in free fall after its engine is shut off and ignore effects of air resistance. What is the maximum height above ground reached by the helicopter?

Powers deploys a jet pack strapped on his back 7.0 s after leaving the helicopter, and then he has a constant downward acceleration with magnitude 2.0 m/s/s. How far is Powers above the ground when the helicopter crashes into the ground?